



## AIR PRESSURE SENSING SWITCH KIT WITH ADJUSTABLE SET POINT

### APPLICATION

The **Series RSS-495-011 Sensing Switch Kit** provides an economical and convenient solution for many residential and light commercial HVAC applications. The kit contains a compact **Series RSS-495** switch with an adjustable set point range of 0.20" w.c. to 1.0" w.c. The switch has been factory set to actuate on a pressure rise of 0.20" w.c. The switch has a bleed hole (.016") in the mounting pan. The individually boxed kit includes a P/N 28419 hex wrench ( $\frac{1}{16}$ " for field calibration, a P/N 28429 tube-to-tube reduction adapter, and two (2) P/N 27577-037 slotted hex head mounting screws (#6 x  $\frac{3}{8}$ ").

### GENERAL DESCRIPTION & OPERATION

The **RSS-495** switch has a thermoplastic housing containing a diaphragm and snap-acting switch. Duo-barbed sample line connectors on each side of the diaphragm accept  $\frac{1}{4}$ " ID or  $\frac{3}{8}$ " ID slip-on flexible tubing. The .016" bleed hole in the mounting pan (low pressure side) prevents the build up of condensation in the switch and sample line.

The electrical connection consists of three (3) male 90° quick-connect terminals. The snap action switch can be actuated by a positive or negative pressure, or by a pressure differential.

### MOUNTING (FIGURE 1)

Select a mounting location that is free from vibration. Mount with the diaphragm in any vertical plane in order to maintain the specified operating set point. Do not mount with the sample line connections directed upward. Surface mount via the two 0.14" slots in the integral foot bracket, using the two (2) slotted hex head mounting screws (#6 x  $\frac{3}{8}$ ") provided in the kit.

### AIR SAMPLING CONNECTION (FIGURE 2)

Refer to **Figure 2** to identify the **High inlet (H)** and the **Low inlet (L)**. Connect the sample lines as follows:

**Positive Pressure Only:** Connect the sample line to **H**; **L** remains open to the atmosphere.

**Negative Pressure Only:** Connect the sample line to **L**; **H** remains open to the atmosphere.

**Two Negative Samples:** Connect higher negative sample to **L**; lower sample to **H**.

**Two Positive Samples:** Connect higher positive sample to **H**; lower sample to **L**.

**One Positive and One Negative:** Connect positive sample to **H**; connect negative sample to **L**.

### ELECTRICAL CONNECTIONS (FIGURE 3)

Before pressure is applied to the diaphragm, the switch contacts will be in the normally closed (**NC**) position as shown in Figure 3.

Connect the application wiring to the corresponding switch terminals, **NC**, **NO**, and **C**.

### FIELD ADJUSTMENT (FIGURE 4)

The adjustable set point range of the **RSS-495** is 0.20" w.c. to 1.0" w.c.,  $\pm 0.05$ " w.c. The switch leaves the factory calibrated at 0.20" w.c. To adjust the set point, insert the  $\frac{1}{16}$ " hex wrench (provided with the kit) into the adjusting screw located between the mounting feet on the underside of the switch. Holding the switch so that the diaphragm is vertical, rotate the adjusting screw clockwise to the desired set point. The maximum number of turns is 4- $\frac{1}{2}$ , covering

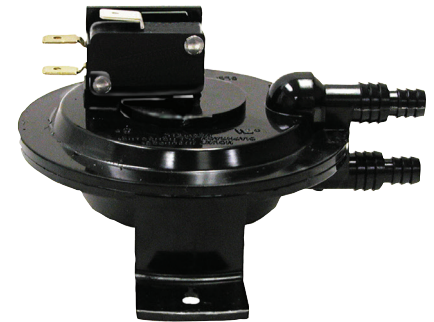

the set point range of 0.20" w.c. to 1.0" w.c. **Do not exceed the maximum number of turns.** Each full turn represents approximately 0.18" w.c. Determine the number of turns required to approximately position the adjusting screw as follows:

$$\frac{(\text{REQUIRED SET POINT} - \text{INITIAL SET POINT @ 0.20})}{0.18}$$

= NUMBER OF TURNS CLOCKWISE

### EXAMPLE:

$$\text{REQUIRED SET POINT} = 0.65" \text{ w.c.}$$

$$\text{INITIAL (FACTORY) SET POINT} = 0.20" \text{ w.c.}$$

$$(0.65 - 0.20) / 0.18 = 2.5 \text{ TURNS}$$

### Please note:

(1) Use a digital manometer and multi meter (such as the **Cleveland Controls Series 6650 Digital Manometer**) to achieve precise set point calibration. Have the **RSS-495** switch as close to actual operating temperature as possible during the calibration. The **Cleveland Controls Series PVG-1 Pressure/Vacuum Generator** provides a handy air source for calibration.

(2) **Warning: Never place an air pressure sensing switch into operation without confirming the set point first. An incorrect setting could result in a hazardous condition.**

Fig. 1

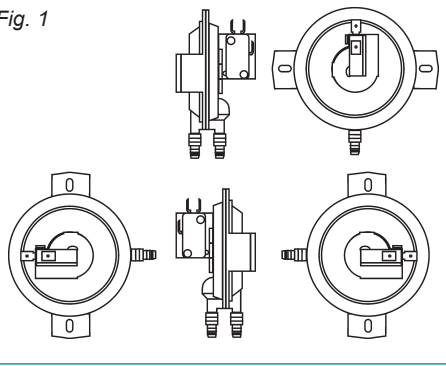

Fig. 2

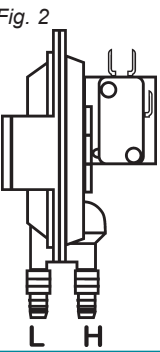

Fig. 3

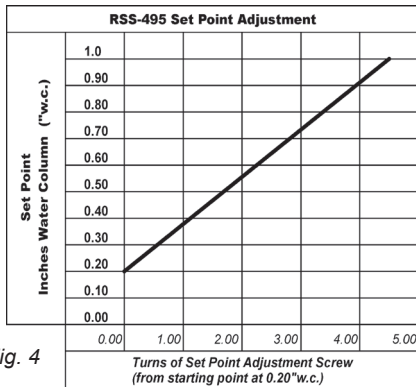
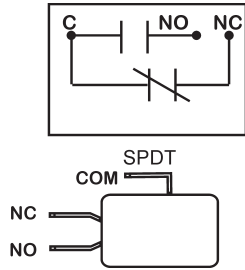

Fig. 4

**Fig. 1:** Mount with the diaphragm in any vertical plane. Sample line connections must not point upward.

**Fig. 2 (left):** Duo barbed sample line connectors located on either side of the diaphragm accept 1/4" ID or 3/8" ID flexible, slip-on tubing.

**Fig. 3 (right):** Before pressure is applied to the diaphragm, the switch contacts are in the NC position, as shown here.

**Fig. 4:** Turns of the set point adjustment screw.

### CONTENTS OF KIT CARTON

- (1) RSS-495 switch
- (1) P/N 27577-037 slotted hex screw, #6 x 3/8"
- (1) P/N 28419 hexagon key, short arm, 1/16"
- (1) P/N 28429 reduction connector, tube to tube
- (2) P/N 27577-037 switch mounting screws, slotted hex, #6-3/8"
- (1) Bulletin LT-RSS-495-011-xx

### Nominal Dimensions in Inches (Millimeters)

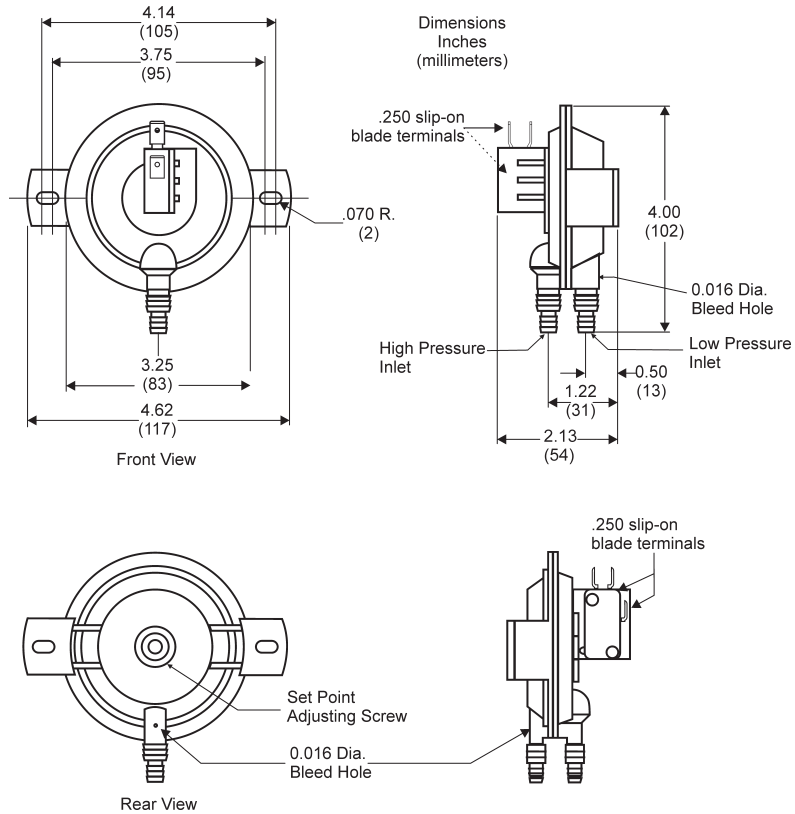

### CARBON MONOXIDE (CO) GAS EXPOSURE CAN CAUSE BRAIN DAMAGE OR DEATH

This pressure switch may control air flow into the combustion chamber. Improper adjustment of the pressure switch in the field, or use of the switch for an application for which it was not intended, may introduce carbon monoxide into the ventilation system or combustion chamber. The U.S. Consumer Product Safety Commission warns that carbon monoxide gas is an "invisible killer." Carbon monoxide (CO) is a colorless, odorless, deadly gas produced by burning fuel, including natural gas and propane. Symptoms of carbon monoxide exposure include dizziness, headache, nausea, weakness, sleepiness, muscle twitching, vomiting and inability to think clearly. If you experience these symptoms, turn the HVAC system off, exit the building, and get into fresh air immediately. The pressure switch must be tested thoroughly by an HVAC professional before the HVAC system is restarted. Proper installation, operation and maintenance of fuel-burning appliances and HVAC systems is the most important factor in reducing carbon monoxide poisoning. For safe operation, be sure all such devices are installed by professionals and operated according to manufacturer's instructions and applicable local codes. Have HVAC systems (including pressure switches) inspected and serviced annually by a trained service technician. Examine vents regularly for improper connections, visible cracks, rust or stains, and blockage.

Install battery-operated carbon monoxide alarms certified to the requirements of the most recent UL, IAS and CSA standard for carbon monoxide alarms. Test the alarms regularly and replace the batteries annually. If you have any questions regarding the installation, use or safety of this switch, please call Cleveland Controls Customer Service at (216) 398-0330.

### SPECIFICATIONS MODEL RSS-495-011 CONTRACTOR KIT

#### Mounting Position:

Mount with the diaphragm in any vertical plane.

#### Field Adjustable Set Point Range:

0.20 ± 0.05" w.c. to 1.0 ± 0.05" w.c.

#### Factory Set Point for RSS 495-011:

Ships factory set at 0.20" w.c. ± 0.05" w.c.

#### Measured Media:

Air or combustion by-products that will not degrade polyisoprene and thermoplastic

#### Maximum Pressure:

1 psi (0.06 bar)

#### Operating Temperature Range:

-40 °F to 190 °F (-40 °C to 88 °C)

#### Life:

100,000 cycles minimum at 1 psi maximum pressure each cycle and at maximum rated electrical load

#### Electrical Rating:

5 amp noninductive 120 to 277 VAC  
1 amp pilot duty (120 Va) at 120 VAC

#### Contact Arrangement: SPDT

#### Electrical Connections:

(3) male 90° 1/4" quick-connect spade terminals, in compliance with NEMA standards.

#### Sample Line Connectors:

Barbed fittings accept 1/4" ID or 3/8" ID flexible, slip-on tubing.

#### Approvals: UL, CUL, CSA, CE,

Australian Gas Association.

#### Shipping Weight: 1/4 lb., approx.